

# BUCKLING OF WOOD STRUCTURAL PANEL SHEATHING



Number D481 • June 2005

Buckling of wood structural panel sheathing such as plywood or oriented strand board (OSB) occasionally results when increased moisture conditions cause the wood to expand. Such buckling may occur between supports or between nails along supports. Although structural properties are unaffected, the waviness affects the building's appearance and may lead to complaints. Builders can significantly reduce the potential for buckling by assuring minimal moisture-content increase in service and/or providing for its natural effects.

## MECHANISM OF BUCKLING

All wood-based products absorb moisture from or give up moisture to the environment until they reach a moisture content in equilibrium with their surroundings. This results in swelling or shrinking of the wood. For solid wood, this expansion is 20 to 40 times as great across the grain as along the grain. Structural panels have good dimensional stability because the tendency of individual veneers or strands to swell or shrink crosswise is greatly restricted by the adjacent veneers or strands.

In typical sheathing applications, relative humidity might vary between 40% and 80%, with corresponding equilibrium moisture content of the panels ranging between 6% and 14%. Total dimensional change of an unrestrained 48" x 96" panel exposed to this range of conditions typically averages 1/8" in width or length. If the panel actually gets wet, dimensional change could be slightly greater. Dimensional change in installed panels is partially restrained by fasteners and framing.

The tendency of expansion to cause buckling in structural panels is related to mechanical properties, physical properties and natural characteristics of wood. It is also a function of not spacing panel ends and edges to allow for expansion. Mechanical properties such as panel stiffness relative to the length of span are important. For a given span, a thin panel has a greater tendency to buckle upon expansion than a thicker panel. Physical properties and characteristics of the panel include the natural growth variability of wood, moisture absorption rate of the wood, and panel variables such as species and orientation of veneers or strands. Some of these inherent panel properties are linked to the natural characteristics of wood and are generally either impossible or impractical to control. Therefore, the user should attempt to prevent high moisture conditions by providing adequate ventilation, and also to minimize the effects of moisture by using recommended panel joint spacing and adequate fastening.

## DESIGN AND CONSTRUCTION FEATURES THAT REDUCE BUCKLING

### Moisture Control

The first step in the prevention of sheathing buckling is to provide adequate moisture control. Ventilation requirements for attics and roof structural spaces, as well as crawl spaces, are usually covered in the building codes. Typical is the One & Two Family Dwelling Code (OTFDC) which requires a *minimum* free area opening (after deducting for screening or louvers) of 1/150 the attic area for natural ventilation. The OTFDC also provides that the required vent area may be reduced by 50% when a ceiling vapor barrier is used, or when half of the required vent area is located in the upper half of the space to be ventilated. Note that these are *minimum* code requirements, which have been found to be adequate under most normal circumstances. However, ventilation in excess of these minimums may be necessary when unplanned moisture is introduced, as by venting an appliance, such as a clothes dryer, into the attic (not recommended), or when moisture-laden air is introduced to the attic by “whole-house” fans.

What may normally be adequate attic ventilation is sometimes inadvertently made ineffective or useless due to poor construction practices during new construction, remodeling or retrofit. It is not uncommon to find the ceiling insulation blocking off the soffit vents. Baffling should be provided at the eaves to prevent the insulation, particularly loose fill types, from drifting over the vent openings. Another poor practice is to vent kitchens or bathrooms directly into the attic, adding extra moisture-laden air that must be exhausted to the outside by ventilation. Instead, such venting should be ducted all the way through the roof, or walls, to the outside.

Some construction features, such as flat roofs, don't lend themselves to good circulation of air even where code-required vent openings are provided. In these cases an efficient ceiling vapor barrier is essential, installed so that any penetrations such as light fixtures are carefully sealed by caulk or tape to prevent moisture-laden air movement from the interior of the building.

## PANEL INSTALLATION

Sheathing panels require aligned, level framing for a nailing surface. Any misalignment between adjacent trusses or rafters will cause the panel to bend, resulting in a wavy appearance. Many reported claims of panel buckling have, upon thorough field inspection, been traced to misaligned trusses or rafters. Misalignment of trusses or rafters can occur from faulty truss fabrication, poor workmanship during construction, or from warping, shrinking or swelling of lumber after construction. Regardless of the cause, misaligned trusses or rafters impact the long-term appearance of wood roofs.

It is important that end and edge joints be properly spaced during sheathing installation. No matter what steps are taken to protect or seal panel faces and edges, panels will expand or shrink slightly with changes in moisture content. If expansion is prevented by tightly butted joints, resulting compression of the panel could lead to buckling. Spacing of 1/8" is recommended at all panel edges and ends, or as required by the panel manufacturer.\* Use of spacer-type panel clips, as shown in Figure 1, will assist in obtaining proper edge spacing. Some builders fashion a spacer tool to assure proper spacing.

Close attention should be paid to proper nail size and spacing and, of course, to assure that fasteners do not miss the supports. Fasteners should be 3/8 inch from panel ends and edges. For ordinary sheathing applications, nail spacings of 6" o.c. at all supported edges and 12" o.c. at intermediate supports have been found adequate to hold panels flat under most conditions. Other nail spacings may be required for engineered construction such as diaphragms.

To the extent possible, structural panel sheathing should be protected from direct moisture, both before and after installation. Cover sheathing with shingle underlayment (or No. 15 roofing felt) as soon as possible to minimize roof sheathing exposure to weather, unless otherwise recommended by sheathing manufacturer. Further equilibration with surrounding air is desirable prior to application of the roof covering (consult shingle manufacturer's recommendations).

FIGURE 1

Spacer-type panel clip

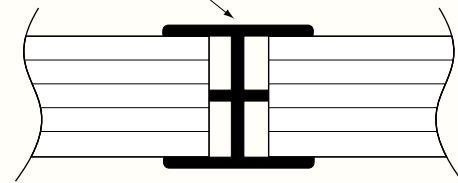

**Note:** Panel spacing is an **APA RECOMMENDATION**, but not a code requirement,\* to provide installers with a means of minimizing the potential for panel buckling which can lead to an unsightly appearance and customer complaints. Panel buckling may be an aesthetic or serviceability issue but is not a structural deficiency. There is no reason to expect this recommended space to be maintained when the panels become acclimated. Gaps that were initially present may have closed due to normal moisture-related expansion. If the flatness of sheathing or flooring panels is acceptable, APA would generally recommend that any finish flooring, siding or roofing be installed as planned regardless of whether gaps are present.

\*Some manufacturers may require a space at the time of installation.

## CORRECTION OF PANEL BUCKLING

If buckling has occurred, assure first that waviness is not actually caused by poor alignment or warping of framing members. Misaligned trusses or rafters make the sheathing appear wavy as if it has buckled. Check for proper alignment by using a taut line or straightedge. Also verify that the panels are properly fastened to the framing.

If panel buckling has indeed occurred, attempt to identify and correct the cause of increased moisture conditions. For example, if roof sheathing buckled prior to roofing, high moisture content due to extreme weather and/or inadequate spacing of panel joints may have been the cause and, once corrected, buckling would not be expected to happen again. However, if buckling occurs after roofing, and after the building is occupied, excessive moisture from within, or inadequate ventilation, should be suspected and the cause located and corrected.

No technique has yet been identified as 100% effective in correcting buckling once it has occurred. However, several techniques have met with some success:

- 1) Space heaters or fans may be used to dry sheathing quickly. Some recovery may be expected, perhaps enough to be acceptable.
- 2) Tightly butted edges or ends of structural panels may be saw-kerfed to relieve pressure and provide a gap for expansion.
- 3) Blocking may be added under unsupported panel edges or under buckled areas. Sheathing may then be flattened by nailing or screwing to the blocking.
- 4) A panel clip may be inserted at the joint between buckled panels to bring them into alignment. This may be done by cutting a small hole at the joint with a hole saw, as shown in Figure 2, inserting the clip and sliding it to the location desired.

Where roofing has already been applied, align panels by installing a cleat with screws from below, as in Figure 3.

- 5) Where buckling occurs between fasteners, more fasteners may be added to bring the panel down to supports. If buckling between fasteners is severe, a saw kerf might be cut from the panel edge inward for a short distance to relieve pressure, as shown in Figure 4.

FIGURE 2

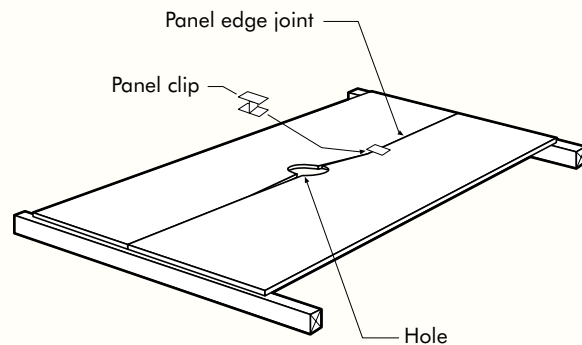

FIGURE 3

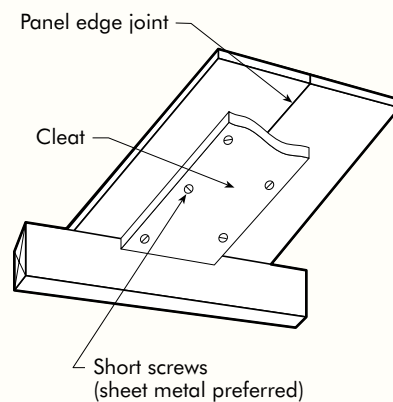
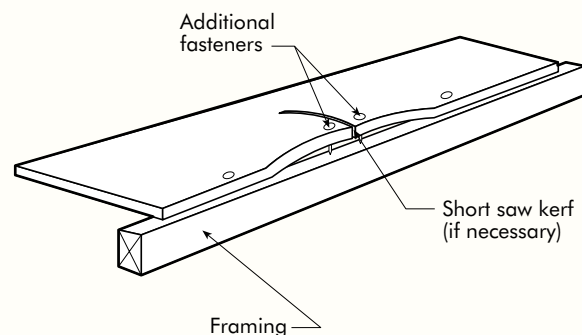

FIGURE 4



We have field representatives in many major U.S. cities and in Canada who can help answer questions involving APA trademarked products. For additional assistance in specifying engineered wood products, contact us:

**APA – THE ENGINEERED  
WOOD ASSOCIATION  
HEADQUARTERS**

7011 So. 19th St.  
Tacoma, Washington 98466-5333  
(253) 565-6600 ▪ Fax: (253) 565-7265

Web Address:  

[www.apawood.org](http://www.apawood.org)

**PRODUCT SUPPORT HELP DESK**

(253) 620-7400  
E-mail Address: [help@apawood.org](mailto:help@apawood.org)

**DISCLAIMER**

*The information contained herein is based on APA – The Engineered Wood Association's continuing programs of laboratory testing, product research, and comprehensive field experience. Neither APA, nor its members make any warranty, expressed or implied, or assume any legal liability or responsibility for the use, application of, and/or reference to opinions, findings, conclusions, or recommendations included in this publication. Consult your local jurisdiction or design professional to assure compliance with code, construction, and performance requirements. Because APA has no control over quality of workmanship or the conditions under which engineered wood products are used, it cannot accept responsibility for product performance or designs as actually constructed.*

Revised June 2005

