

## ICC-ES Evaluation Report

ESR-2913

Issued July 1, 2009

*This report is subject to re-examination in one year.*[www.icc-es.org](http://www.icc-es.org) | (800) 423-6587 | (562) 699-0543

A Subsidiary of the International Code Council®

DIVISION: 06—WOOD AND PLASTICS  
Section: 06170—Prefabricated Structural Wood

## REPORT HOLDER:

MURPHY ENGINEERED WOOD PRODUCTS DIVISION  
412 WEST CENTRAL  
SUTHERLIN, OREGON 97479  
(541) 459-4545  
[www.murphyplywood.com](http://www.murphyplywood.com)

## EVALUATION SUBJECT

MURPHY LAMINATED VENEER LUMBER (LVL)

## 1.0 EVALUATION SCOPE

## Compliance with the following codes:

- 2006 *International Building Code*® (IBC)
- 2006 *International Residential Code*® (IRC)

## Property evaluated

Structural

## 2.0 USES

Murphy LVL is an alternative to sawn lumber for structural applications including beams, headers, joists and rafters. Murphy LVL is also used for components of built-up structural members, such as flanges for I-joists and chords for trusses.

## 3.0 DESCRIPTION

## 3.1 General:

Murphy LVL complies with the requirements noted in Section 2303.1.9 of the IBC for allowable stress design (Section 2301.2). Chapters 5 and 8 of the IRC are applicable to Murphy LVL.

The wood veneer properties and species, adhesive, manufacturing parameters, and finished product thickness, width and length must meet the requirements noted in the quality manual that contains the manufacturing standard.

## 3.2 Material:

Murphy LVL is made with layers of wood veneers laminated together using an exterior-type phenol-formaldehyde adhesive conforming to ASTM D 2559. Murphy LVL is available in thicknesses from 1<sup>1</sup>/<sub>4</sub> inches (32 mm) to 3<sup>1</sup>/<sub>2</sub> inches (89 mm), depths from 1<sup>1</sup>/<sub>2</sub> inches (39 mm) to 48 inches (1219 mm), and lengths up to 80 feet (24 m).

## 4.0 DESIGN AND INSTALLATION

## 4.1 Design:

**4.1.1 General:** Murphy LVL is designed as solid-sawn lumber in accordance with the applicable code and the National Design Specification for Wood Construction (NDS). Reference design values are as noted in Table 1.

**4.1.2 Fasteners:** Reference design values for connections must be determined in accordance with the applicable section of the NDS, using the equivalent specific gravities provided in Table 2. Spacing, edge distance and end distance of fasteners installed in the faces and edges of Murphy LVL members must be in accordance with the NDS and are limited as shown in Table 3.

## 4.2 Installation:

Murphy LVL must be installed in accordance with this evaluation report, applicable building codes and the specifications of the design professional responsible for the design of the structure. Drawings and/or the manufacturer's published installation instructions must be available on the jobsite during installation.

## 5.0 CONDITIONS OF USE

The Murphy LVL described in this report complies with, or is a suitable alternative to what is specified in, those codes listed in Section 1.0 of this report, subject to the following conditions:

- 5.1** Calculations and drawings demonstrating compliance with this report must be submitted to the code official. The calculations and drawings must be prepared by a registered design professional where required by the statutes of the jurisdiction in which the project is to be constructed.
- 5.2** The material is limited to conditions in which its moisture content will be less than 16 percent.
- 5.3** Connections other than the nailed and bolted connections described in this report are outside of the scope of this report.
- 5.4** Evaluation of the effect of fire-retardant or preservative treatment on LVL is outside the scope of this report.
- 5.5** Installation, fabrication, identification and connection details must be in accordance with this report, the manufacturer's published installation instructions and the applicable code. This report must govern if there are conflicts between the manufacturer's published installation instructions and this report.

5.6 Murphy LVL is produced in Sutherlin, Oregon, under a quality control program with inspections by APA—The Engineered Wood Association (AA-649).

6.0 EVIDENCE SUBMITTED

Data in accordance with the ICC-ES Acceptance Criteria for Structural Wood-based Products (AC47), dated June 2009.

7.0 IDENTIFICATION

The Murphy LVL must be identified with stamps bearing the Murphy Engineered Wood Division name; grade; evaluation report number (ESR-2913); the production shift and date of manufacture; and the name of the inspection agency [APA—The Engineered Wood Association (AA-649)].

TABLE 1—DESIGN PROPERTIES (ALLOWABLE STRESS DESIGN) FOR MURPHY LVL<sup>1, 2, 3</sup>

| PROPERTY                                                 |                    | DESIGN STRESS (psi)       |                            |                            |                            |                            |
|----------------------------------------------------------|--------------------|---------------------------|----------------------------|----------------------------|----------------------------|----------------------------|
|                                                          |                    | 2,250F <sub>b</sub> -1.5E | 2,750 F <sub>b</sub> -1.8E | 2,850 F <sub>b</sub> -1.9E | 2,950 F <sub>b</sub> -2.0E | 3,150 F <sub>b</sub> -2.0E |
| Bending (F <sub>b</sub> )                                | Joist <sup>4</sup> | 2,250                     | 2,750                      | 2,850                      | 2,950                      | 3,100                      |
|                                                          | Plank              | 2,200                     | 2,750                      | 2,800                      | 2,950                      | 3,100                      |
| Tension parallel to grain (F <sub>t</sub> ) <sup>5</sup> |                    | 1,350                     | 1,950                      | 1,950                      | 2,100                      | 2,100                      |
| Longitudinal shear (F <sub>v</sub> )                     | Joist              | 285                       | 285                        | 285                        | 290                        | 290                        |
|                                                          | Plank              | 150                       | 150                        | 150                        | 150                        | 150                        |
| Compression parallel (F <sub>c  </sub> )                 |                    | 2,350                     | 2,350                      | 2,350                      | 3,200                      | 3,200                      |
| Compression perpendicular (F <sub>c⊥</sub> )             | Joist              | 750                       | 750                        | 750                        | 750                        | 750                        |
|                                                          | Plank              | 450                       | 450                        | 550                        | 550                        | 550                        |
| Modulus of Elasticity, E                                 | Joist              | 1.5 x 10 <sup>6</sup>     | 1.8 x 10 <sup>6</sup>      | 1.9 x 10 <sup>6</sup>      | 2.0 x 10 <sup>6</sup>      | 2.0 x 10 <sup>6</sup>      |
|                                                          | Plank              | 1.4 x 10 <sup>6</sup>     | 1.8 x 10 <sup>6</sup>      | 1.9 x 10 <sup>6</sup>      | 2.0 x 10 <sup>6</sup>      | 2.0 x 10 <sup>6</sup>      |

For SI: 1 psi = 6.9 kPa.

<sup>1</sup>The tabulated values are design values for normal duration of load. All values, except for E and F<sub>c⊥</sub>, may be adjusted for other load durations as permitted by the code. The design stresses are limited to conditions in which the maximum moisture content is less than 16 percent.

<sup>2</sup>Reference design values must be adjusted, as applicable, in accordance with Section 8.3 of the NDS.

<sup>3</sup>Joist = load parallel to glueline. Plank = load perpendicular to glueline.

<sup>4</sup>The tabulated values are based on a reference depth of 12 inches. For other depths, when loaded edgewise, the allowable bending stress (F<sub>b</sub>) shall be modified by (12/d)<sup>0.18</sup> where d = depth in inches. For depths less than 2 1/2 inches, the factor for the 2 1/2-inch depth must be used.

<sup>5</sup>The values published in Table 1 are based on a reference length of 3 feet. For other lengths, the allowable tensile stress must be modified by (3/ℓ)<sup>0.11</sup>, where ℓ = length in feet. For lengths less than 3 feet, the unadjusted allowable tension stresses in Table 1 are used.

TABLE 2—FASTENER DESIGN FOR MURPHY LVL: EQUIVALENT SPECIFIC GRAVITY<sup>1</sup>

| NAILS             |                   |                   |                   | BOLTS             |                        |
|-------------------|-------------------|-------------------|-------------------|-------------------|------------------------|
| Withdrawal Load   |                   | Lateral Load      |                   | Lateral Load      |                        |
| Installed in Edge | Installed in Face | Installed in Edge | Installed in Face | Installed in Face |                        |
|                   |                   |                   |                   | Parallel to Grain | Perpendicular to Grain |
| 0.49              | 0.50              | 0.50              | 0.50              | 0.50              | 0.50                   |

<sup>1</sup>Fastener values based on the equivalent specific gravities in the above table are for normal load duration and may be adjusted using the load duration factors in accordance with the code.

TABLE 3—MINIMUM ALLOWABLE NAIL SPACINGS FOR MURPHY LVL<sup>1</sup>

| THICKNESS (in.)                                                           | ORIENTATION       | NAIL SIZE <sup>2,3</sup><br>(COMMON OR BOX) | MINIMUM END<br>DISTANCE (in.)              | MINIMUM NAIL SPACING (IN.) |                              |
|---------------------------------------------------------------------------|-------------------|---------------------------------------------|--------------------------------------------|----------------------------|------------------------------|
|                                                                           |                   |                                             |                                            | Single Row                 | Multiple Rows <sup>4,5</sup> |
| 1 <sup>1</sup> / <sub>4</sub> ≤ thickness < 1 <sup>1</sup> / <sub>2</sub> | Edge <sup>6</sup> | 8d and smaller                              | 2 <sup>1</sup> / <sub>2</sub>              | 4                          | NR <sup>8</sup>              |
|                                                                           |                   | 10d and 12d                                 | 2 <sup>1</sup> / <sub>2</sub>              | 4                          |                              |
|                                                                           |                   | 16d                                         | 3 <sup>1</sup> / <sub>2</sub>              | 5                          |                              |
|                                                                           | Face <sup>7</sup> | 8d and smaller                              | 1 <sup>1</sup> / <sub>2</sub>              | 3                          | 3                            |
|                                                                           |                   | 10d and 12d                                 | 1 <sup>1</sup> / <sub>2</sub>              | 3                          | 3                            |
|                                                                           |                   | 16d                                         | 1 <sup>1</sup> / <sub>2</sub>              | 5                          | 5                            |
| ≥ 1 <sup>1</sup> / <sub>2</sub>                                           | Edge <sup>6</sup> | 8d and smaller                              | 2 <sup>1</sup> / <sub>2</sub>              | 3                          | 4                            |
|                                                                           |                   | 10d and 12d                                 | 3 <sup>1</sup> / <sub>2</sub> <sup>9</sup> | 4                          | 5                            |
|                                                                           |                   | 16d                                         | 3 <sup>1</sup> / <sub>2</sub>              | 5                          | 6 <sup>10</sup>              |
|                                                                           | Face <sup>7</sup> | 8d and smaller                              | 1 <sup>1</sup> / <sub>2</sub>              | 3                          | 3                            |
|                                                                           |                   | 10d and 12d                                 | 1 <sup>1</sup> / <sub>2</sub>              | 3                          | 3                            |
|                                                                           |                   | 16d                                         | 1 <sup>1</sup> / <sub>2</sub>              | 5                          | 5                            |

For SI: 1 inch = 25.4 mm.

<sup>1</sup>Edge distance must be sufficient to prevent splitting.

<sup>2</sup>16d sinkers (0.148 inch x 3<sup>1</sup>/<sub>4</sub> inches) may be spaced the same as a 12d common wire nail (0.148 inch x 3<sup>1</sup>/<sub>4</sub> inches).

<sup>3</sup>Fastener sizes and closest on-center spacing not specifically described above are beyond the scope of this report.

<sup>4</sup>Multiple rows in the edge orientation must be spaced 1/2 inch or more from each other and offset one-half of the tabulated minimum nail spacing, as shown in Figure 1.

<sup>5</sup>Multiple rows must be equally spaced from the centerline of the narrow face axis.

<sup>6</sup>Nail penetration for edge nailing must not exceed 2 inches for 16d nails (common or box) or 2<sup>1</sup>/<sub>2</sub> inches for 10d and 12d nails (common or box).

<sup>7</sup>Tabulated closest on-center spacing for face orientation is applicable to nails that are installed in rows parallel to the grain (length) of the LVL. For nails installed in rows perpendicular to the direction of grain (width/depth) of the LVL, the closest on-center spacing for face orientation must be sufficient to prevent splitting of the LVL.

<sup>8</sup>Not recommended.

<sup>9</sup>Minimum end distance may be reduced to 2<sup>1</sup>/<sub>2</sub> inches for single row nailing.

<sup>10</sup>Minimum nail spacing may be reduced to 5 inches when the LVL is 1<sup>3</sup>/<sub>4</sub> inches or thicker.

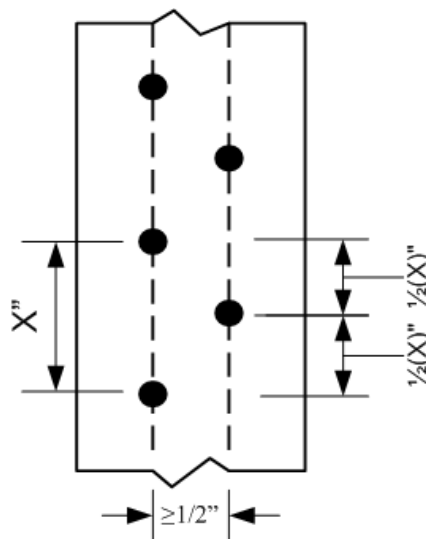

FIGURE 1