

Murphy Laminated Veneer Lumber
Murphy Engineered Wood Division

PR-L283
Revised February 17, 2010

Product: 2250F_b-1.5E, 2750F_b-1.8E, 2850F_b-1.9E, 2950F_b-2.0E, and 3100F_b-2.0E Murphy LVL
Murphy Engineered Wood Division, 412 West Central, Sutherlin, Oregon 97479
(541) 459-4545

www.murphyplywood.com

1. Basis of the product report:
 - 2009 and 2006 International Building Code (IBC): Sections 104.11 Alternative Materials and 2303.1.9 Structural composite lumber
 - 2009 and 2006 International Residential Code (IRC): Section R104.11 Alternative Materials
 - ASTM D 5456-05a and ASTM D 5456-03 recognized by the 2009 and 2006 IBC, respectively
 - APA Reports T2008P-10, T2008P-31, T2008P-43, T2008P-113, T2009P-12, T2009P-15, T2010P-02, and other qualification data
2. Product description:

Murphy laminated veneer lumber (LVL) is made with wood veneers laminated with grain parallel to the length of the member in accordance with the in-plant manufacturing standard approved by APA. Murphy LVL is available with thicknesses up to 3-1/2 inches, widths up to 24 inches, and lengths up to 80 feet.
3. Design properties:

Table 1 lists the design properties, Table 2 lists the equivalent specific gravities for connection design, and Table 3 lists the allowable nail spacing for Murphy LVL. The allowable spans for Murphy LVL shall be determined based on the information provided in this report and/or based on recommendations provided by the manufacturer (<http://murphyplywood.com/downloads/6797%20Murphy%20LVL%20TG%2008-final.pdf>).
4. Product installation:

Murphy LVL shall be installed in accordance with the engineering drawing approved by the engineer of record and/or recommendations provided by the manufacturer. Permissible details and allowable hole sizes shall be in accordance with the engineering drawing and/or recommendations provided by the manufacturer.
5. Fire-rated assemblies:

The provisions of IBC Section 721.6.3, design of fire-resistant exposed wood members, shall be applicable to Murphy LVL. Fire-rated assemblies shall be constructed in accordance with the recommendations provided by APA Design/Construction Guide: *Fire-Rated Systems*, Form W305 (www.apawood.org/publications) and the manufacturer.
6. Limitations:
 - a) Murphy LVL shall be designed in accordance with the code using the design properties specified in this report.
 - b) Murphy LVL is limited to dry service conditions where the average moisture content of sawn lumber is less than 16 percent.
 - c) Murphy LVL is produced at the Murphy Engineered Wood Division facilities in Sutherlin, Oregon under a quality assurance program audited by APA.
 - d) This report is subject to re-examination in one year.

7. Identification:

Murphy LVL described in this report are identified by a label bearing the manufacturer's name (Murphy Engineered Wood Division) and/or trademark, the APA assigned plant number (1089), the LVL grade, the APA logo, the report number PR-L283, and a means of identifying the date of manufacture.

Table 1. Design Properties (Allowable Stress Design) for Murphy LVL ^(a,b)

Property		Design Stress (psi)				
		2250F _b -1.5E	2750F _b -1.8E	2850F _b -1.9E	2950F _b -2.0E	3100F _b -2.0E
Bending (F _b) ^(c)	Joist ^(d)	2,250	2,750	2,850	2,950	3,100
	Plank	2,200	2,750	2,800	2,950	3,100
Tension parallel to grain (F _t) ^(e)		1,350	1,950	1,950	2,100	2,100
Longitudinal shear (F _v)	Joist	285	285	285	290	290
	Plank	150	150	150	150	150
Compression parallel (F _c)		2,350	2,350	2,350	3,200	3,200
Compression perpendicular (F _{c⊥})	Joist	750	750	750	750	750
	Plank	450	450	550	550	550
Modulus of Elasticity, E	Joist	1.50 x 10 ⁶	1.80 x 10 ⁶	1.90 x 10 ⁶	2.00 x 10 ⁶	2.00 x 10 ⁶
	Plank	1.40 x 10 ⁶	1.80 x 10 ⁶	1.90 x 10 ⁶	2.00 x 10 ⁶	2.00 x 10 ⁶

For SI: 1 inch = 25.4 mm, 1 foot = 304.8 mm, 1 lbf = 4.448 N, 1 psi = 6.9 kPa.

- (a) The tabulated values are design values for normal duration of load. All values, except for E and F_{c⊥}, are permitted to be adjusted for other load durations as permitted by the code. The design stresses are limited to conditions in which the maximum moisture content of lumber is less than 16 percent.
- (b) Joist = load parallel to glueline. Plank = load perpendicular to glueline.
- (c) Tabulated flexural stress (F_b) may be increased by 4 percent when the member qualifies as a repetitive member as defined in the NDS.
- (d) The tabulated values are based on a reference depth of 12 inches. For other depths, when loaded edgewise, the allowable bending stress (F_b) shall be modified by $(\frac{12}{d})^{0.18}$, as shown in the following table. For depths less than 2-1/2 inches, the factor for the 2-1/2-inch depth shall be used.

Depth (in.)	2-1/2	3-1/2	5-1/2	7-1/4	9-1/4	11-1/4	12	16	18	20	24
Multiply by	1.33	1.25	1.15	1.09	1.05	1.01	1.0	0.95	0.93	0.91	0.88

- (e) The tabulated values are based on a reference length of 3 feet. For other lengths, the allowable tensile stress shall be modified by $(\frac{3}{\ell})^{0.11}$, where ℓ = length in feet. For lengths less than 3 feet, use the allowable tension stresses in Table 1 unadjusted.

Table 2. Fastener Design for Murphy LVL ^(a,b)

Equivalent Specific Gravity (S.G.)				
Nails				Bolts
Withdrawal Load		Lateral Load		Lateral Load
Installed in Edge	Installed in Face	Installed in Edge	Installed in Face	Installed in Face
0.49	0.50	0.50	0.50	0.50

- (a) Fastener values based on the equivalent specific gravities in the above table are for normal load duration and shall be permitted to be adjusted using the load duration factors in accordance with the code.
- (b) The bolt edge distance when loaded parallel and perpendicular to the grain shall be a minimum of four times the bolt diameter.

Table 3. Minimum Allowable Nail Spacings for Murphy LVL^(a)

Thickness (in.)	Orientation	Nail Size ^(b,c) (Common or Box)	Minimum End Distance (in.)	Minimum Nail Spacing (in.)	
				Single Row	Multiple Rows ^(d,e)
1-1/4 ≤ thickness < 1-1/2	Edge ^(f)	8d & smaller	2-1/2	4	NR ^(h)
		10d & 12d	2-1/2	4	
		16d	3-1/2	5	
	Face ^(g)	8d & smaller	1-1/2	3	3
		10d & 12d	1-1/2	3	3
		16d	1-1/2	5	5
≥ 1-1/2	Edge ^(f)	8d & smaller	2-1/2	3	4
		10d & 12d	3-1/2 ⁽ⁱ⁾	4	5
		16d	3-1/2	5	6 ^(j)
	Face ^(g)	8d & smaller	1-1/2	3	3
		10d & 12d	1-1/2	3	3
		16d	1-1/2	5	5

For SI: 1 inch = 25.4 mm.

- (a) Edge distance shall be sufficient to prevent splitting.
- (b) 16d sinkers (0.148" x 3-1/4") may be spaced the same as a 12d common wire nail (0.148" x 3-1/4").
- (c) Fastener sizes and closest on-center spacing not specifically described above are beyond the scope of this report.
- (d) Multiple rows in the edge orientation must be spaced 1/2 inch or more from each other and offset one-half of the tabulated minimum nail spacing, as shown in Figure 1.
- (e) Multiple rows must be equally spaced from the centerline of the narrow face axis.
- (f) Nail penetration for edge nailing shall not exceed 2 inches for 16d nails (common or box) and 2-1/2 inches for 10d and 12d nails (common or box).
- (g) Tabulated closest on-center spacing for face orientation is applicable to nails that are installed in rows parallel to the grain (length) of the LVL. For nails installed in rows perpendicular to the direction of grain (width/depth) of the LVL, the closest on-center spacing for face orientation shall be sufficient to prevent splitting of the LVL.
- (h) Not recommended.
- (i) Minimum end distance may be reduced to 2-1/2 inches for single row nailing.
- (j) Minimum nail spacing may be reduced to 5 inches when the LVL is 1-3/4 inches or thicker.

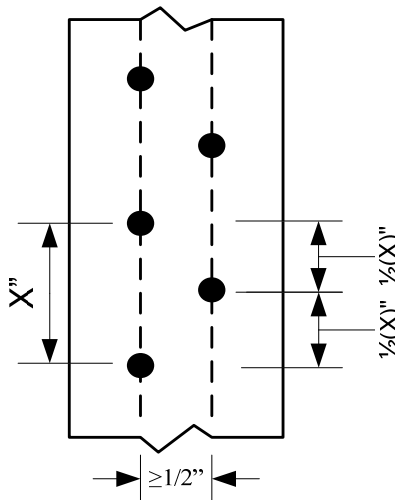

Figure 1. Spacing of multiple rows of nails.

APA – *The Engineered Wood Association* is an accredited certification body under ISO 65 by Standards Council of Canada (SCC) and an accredited inspection agency by the International Code Council (ICC) International Accreditation Service (IAS) under ISO/IEC 17020. APA is also an accredited testing organization recognized by IAS and SCC under ISO/IEC 17025. APA is a recognized testing laboratory by Miami-Dade County, and a Product Testing Laboratory, Product Quality Assurance Entity, and Product Validation Entity by the Florida Department of Community Affairs (DCA).

**APA – THE ENGINEERED WOOD ASSOCIATION
HEADQUARTERS**

7011 So. 19th St. ▪ Tacoma, Washington 98466
Phone: (253) 565-6600 ▪ Fax: (253) 565-7265 ▪ Internet Address: www.apawood.org

PRODUCT SUPPORT HELP DESK
(253) 620-7400 ▪ *E-mail Address:* help@apawood.org

DISCLAIMER

APA Product Report® is a trademark of APA – *The Engineered Wood Association*, Tacoma, Washington. The information contained herein is based on the product evaluation in accordance with the references noted in this report. Neither APA, nor its members make any warranty, expressed or implied, or assume any legal liability or responsibility for the use, application of, and/or reference to opinions, findings, conclusions, or recommendations included in this report. Consult your local jurisdiction or design professional to assure compliance with code, construction, and performance requirements. Because APA has no control over quality of workmanship or the conditions under which engineered wood products are used, it cannot accept responsibility of product performance or designs as actually constructed.